

elson LEAD FREE* SUB WATER METER ASSEMBLY KIT 20mm BALL JOINT (NSW) LF74160

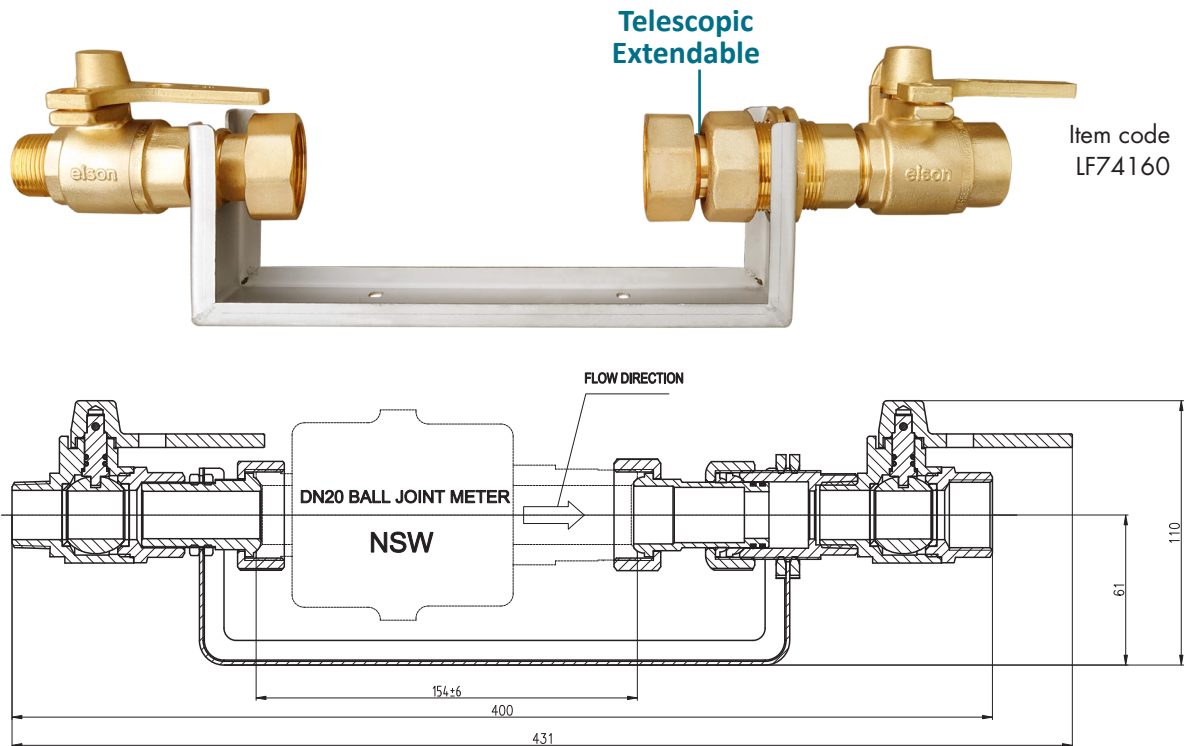

elson Sub Meter Assembly Kits are pre-assembled ready to install for fast installation of water meters that comply with AS3565.1

FEATURES

- LEAD FREE DR BRASS
- Pre-assembled for fast installation
- Each Assembly Kit pressure tested
- Two dual way lockable ball valves. Can be locked opened or closed.
- Telescopic extendable connection with locking nut
- Standardsmark Certificate Number: SMKP26244 in compliance with 4796
- Watermark Certificate Number: WMKA21922 in compliance with AS5830.1
- Suitable for Potable Water – complies with AS/NZS 4020
- Dezincification Resistant (DR) Brass complies with AS 2345
- WSAA Appraised ball valves



WaterMark
WMKA 21922
Standard AS 5830.1



* Elson Lead Free copper alloy products contain less than 0.1% Lead by weight.

Elson Australasia Pty Ltd

ABN 45 059 613 991

Version 2.0 May 2023

38 Eddie Road, Minchinbury NSW 2770

Tel: (02) 9625 7899

Fax: (02) 9625 7855

Email: sales@elson.net.au

elson LEAD FREE* SUB WATER METER ASSEMBLY KIT 20mm BALL JOINT (NSW) LF74160

INSTALLATION INSTRUCTIONS

1. Loosen lock Nut (C), ensure Meter Coupling (D) is movable.
2. Put Water Meter between Nut (A) and Nut (B), then ensure the Water Meter's connector touches ball face of Meter Coupling (E), then tighten Nut (A).
3. Pull Meter Coupling (D) to touch the Water Meter's other connector then tighten Nut (B).
4. Tighten lock Nut (C) to securely fasten the Water Meter.

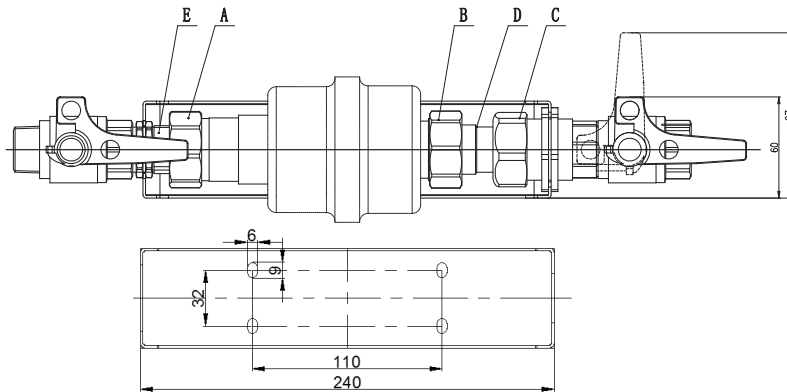

elson Sub Meter Assembly Kits are designed to suit most brands of meters, such as RMC, Hydrus, Elster, Itron and any other meters that comply with AS3565.1 and fit within the tolerances of elson Sub Meter Assembly Kits.

Breach Pieces

The use of a spacer may be necessary in certain installations where the installation is made prior to the water meter being available. The pipe spacer is available for the DN20 BALL JOINT NSW water meter.

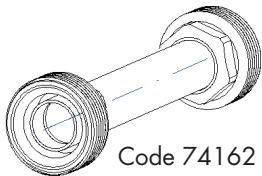

Code 74162 elson SUB METER SPACER DN20 BALL JOINT NSW

TECHNICAL SPECIFICATIONS

- Working Temperature Range: 1 - 95 °C
- Maximum Working Pressure: 2500kPa
- Threads complies with AS ISO 7.1, AS ISO 7.2 and AS 1722.2
- NSW Ball joint Meter Connection
- Complies with Sydney water MLIM guidelines



* Elson Lead Free copper alloy products contain less than 0.1% Lead by weight.

Elson Australasia Pty Ltd

ABN 45 059 613 991

Version 2.0 May 2023

38 Eddie Road, Minchinbury NSW 2770

Tel: (02) 9625 7899

Fax: (02) 9625 7855

Email: sales@elson.net.au